

# General Specifications

RC800D, FLXA402T  
Reagent Type  
Residual Chlorine Analyzer

GS 12F04B10-01EN

## ■ General

Chlorine treatment in water treatment systems, such as municipal water supplies, serves to destroy microorganisms, fungi, aquatic plants and shellfish that live in water, and thus to yield appropriate quality for the application. However, adding too much chlorine cause negative effects; in municipal water supplies, it may give the water an unpleasant chlorine odor; in industry, excessive chlorine may corrode plumbing; and in waste water this may release dangerous substances into streams and rivers. For this reason, it has become very important in recent years to use a residual chlorine analyzer when chlorine is added to water, in order to measure the concentration of chlorine, and to monitor and control this concentration.

Residual Chlorine Analyzer composed of RC800D Reagent type Residual Chlorine Sensor Unit and FLXA402T Liquid Analyzer for Turbidity and Chlorine is suitable for process manager and control at water treatment plant or plant/industrial water facility handling coolant or drinking water and for water quality control of large-scale boilers.

RC800D measures free chlorine or total chlorine by amperometric principle. It employs a polarographic method by rotating gold alloy electrode to provide continuous online measurement.

By appropriate use of reagents, RC800D offers chlorine measurement system featuring separation performance between residual chlorine measurement (free chlorine plus combined chlorine) and free chlorine measurement.

FLXA402T a next-generation analyzer is designed, being tailored from the well-received FLXA402 technical, to provide analysis with user-friendly color HMI and digital communications.

The technology of predictive maintenance prevents accidental shutdown of the factory. These functions help to reduce OPEX. RC800D has drastically improved maintainability and minimized the maintenance time.

## ■ Features

### RC800D

- Inherited the cleaning method with contamination-resistant rotating electrode and beads
- Improved maintainability
  - Easy clean up cell structure
  - Rotation mechanism with belt/slip ring without adjustment
  - Easy to find best condition by monitoring applied voltage and plateau characteristic
- Sampling system (Sand filter system)
  - Selectable appropriate prechlorination treatment system according to user's application.

### FLXA402T

- Diagnosis function
  - Motor rotation monitoring, empty cell detection, sensor condition check (zero point, Slope, stability during calibration)
- Output signal: Linear or Polyline output (4-20 mA)
- Communications
  - Analog output, Digital communication (Modbus RTU or Modbus TCP/IP)
- Multilingual display
  - English, German, French, Chinese, Korean, Spanish, Portuguese, Japanese



FLEXA, FLXA, SENCOM are trademarks or registered trademarks of Yokogawa Electric Corporation.  
All other company and product names mentioned in this document are trademarks or registered trademarks of their respective companies.  
We do not use TM or ® mark to indicate those trademarks or registered trademarks in this document.

## ■ General Specifications

### 1. RC800D Reagent Type Residual Chlorine Sensor Unit

#### ■ Measurement

Free chlorine or residual chlorine (total chlorine) in water

#### ■ Sensor

Measuring method: Amperometric principle (polarographic system with reagent) using rotating gold alloy electrode

Measuring range: 0-10mg/L (minimum range 0-1mg/L)  
Linearity:  $\pm 3\%$  of reading or  $\pm 0.03$  mg/L whichever is greater

(Note) The accuracy of residual chlorine measurement is evaluated based on the result from laboratory analysis for checking measured values in addition to the accuracy of the above equipment.

Repeatability:

$\pm 1\%$  of reading or  $\pm 0.01$  mg/L whichever is greater

(Note) The accuracy of residual chlorine measurement is evaluated based on the result from laboratory analysis for checking measured values in addition to the accuracy of the above equipment.

Effect of combined chlorine:

5% or less, of concentration of combined chlorine for combined chlorine insensitive version

Response time: Displayed as T90 time

For pure water; Approx. 3 min

For raw water; Approx. 4 min

(Within 3 min from standard liquid inlet)

Sample conditions:

Temperature: 0 to 50°C (Temperature compensation range: 0 to 40 °C)

pH: 3 to 9 pH

Flow rate: 1.0 to 4.0 L/min (for pure water)

5.0 to 10.0 L/min (1-cylinder sand filter type)

10.0 to 20.0 L/min (2-cylinder sand filter type)

Pressure: 20 to 500 kPa

Electrode:

Measurement Electrode; Rotating gold alloy electrode

Reference electrode; Platinum electrode (built-in Pt1000  $\Omega$  RTD), the combined chlorine insensitive version uses a silver chloride electrode (built-in Pt1000  $\Omega$  RTD)

Reagents:

Composition: The following reagents are dissolved in pure water to give 100L of solution.

(Note) Pure water should be equal to or exceed level of tap water and should not contain oxidizing and reducing substances such as chlorine.

	For residual chlorine measurement (-T)		For free chlorine measurement (-F)	For combined chlorine measurement (-C)
	Up to 6 mg/L	Over 6 up to 10 mg/L	Up to 10 mg/L	Up to 10 mg/L
Maximum concentration	Up to 6 mg/L	Over 6 up to 10 mg/L	Up to 10 mg/L	Up to 10 mg/L
Potassium iodide, extra pure	500 g	1000 g	—	—
Potassium bromide, extra pure	—	—	4000 g	4000 g
Sodium acetate, extra pure	150 g		1000 g	5400 g
Acetic acid, extra pure	1000 mL		1000 mL	200 mL

Consumption: 1.5 mL/min  $\pm 10\%$

100L reagent is for about 40-45 days measurement.

Automatic cleaning functions: Electrode and flow cell cleaning methods

For pure water: Glass-bead cleaning

For raw water,

Glass-bead cleaning+water jet cleaning

Water jet cleaning flow: 2 to 3 L/min

Sensor error detection:

Over diffusion current value, temperature error, applied voltage error, out of temperature compensation range, Zero calibration error, span calibration error, unstable calibration error, stopped motor rotation, empty cell

#### ■ Electrical

Ratings, Frequency

(code for sampling power supply)

-10: 100 VAC, 50 Hz

-11: 100 VAC, 60 Hz

-20: 200 VAC, 50 Hz

-21: 200 VAC, 60 Hz

Power consumption (including Converter)

(code for sampling power supply)

-1 □: 185 VA

-2 □: 200 VA

-3 □: 230 VA

#### ■ Mechanical and others

Case of smart unit and electrode unit:

Color: Black, Light silver gray (RAL 260 80 05)

Finish; None

Material:

Smart unit: PC (poly carbonate) resin

Electrode unit: m-PPE resin, SUS316

Flow cell: Acrylic resin

Pipe: Polyethylene resin

Protection:

Smart unit: IP65 Type4X

Terminal screw size: M3 (Earth terminal: M4)

Cable gland: \* 5 holes, M20 Cable gland x 5

(For 6.5 to 12.5 mm outer diameter cable)

(Note) Cable gland is installed at the factory.

Piping : Drain (VP40 pipe)

Sample inlet (VP16 pipe)

Conduit adapter (option): G1/2, 1/2NPT or M20  $\times$  1.5

Stainless steel tag plate (option): When you specify Option code /SCT, Tag plate on which the number is printed is shipped with product. You can attach this tag by wire.

Warm up time: Approx. 30 min

#### ■ Sampling system, others

Sand filter:

Filter sand: Filter sand for water treatment (rapid filtering sand, approx. 550 mL per cylinder)  
Filtering flow: Approx. 500 mL/min (per cylinder)  
Backwash water flow: 8 to 9 L/min (per cylinder)

Stand:

Stand materials: Carbon steel or stainless steel

Paint colors:

Mounting stand: Munsell 0.6GY3.1/2.0

Other parts: Munsell 0.6GY3.1/2.0 and 2.5Y8.4/1.2

Finish: Baked polyurethane resin coating

Operating conditions: (Including RC800D and FLXA402T)

Ambient temperature: -5 to 55°C

(Required Anti-freezing measures if the sample or reagent could be frozen.)

Ambient humidity: 10 to 90% RH at 40°C

(No condensation)

Storage temperature: -30 to 70°C

Installation: Indoors (A separate rainproof cover is required for outdoor installation. Required a roof to avoid direct sunshine)

Utilities

Power supply: 100/110/220 V AC  $\pm 10\%$ , 50/60 Hz

Cleaning water (required with sand filter system):

Quality; clean water

Pressure; 100 to 500 kPa

Flow; 10 to 12 L/min

Consumption;

Approx. 130 L/day (1-cylinder sand filter type)

Approx. 470 L/day (2-cylinder sand filter type)

(With standard cleaning sequence [factory settings])

Constant flow rate Liquid pump:

Sample flow: 50 mL/min $\pm 10\%$

Reagent flow: 1.5 mL/min $\pm 10\%$

Purging Air (using instrument air):

Supply pressure; 140 kPa

Air consumption; Approx. 4 L/min

Pump for Purging Air (if instrument air cannot be used):

Install to enable intake of clean air.

Intake/discharge: 4 L/min, at 50 Hz (Intake/discharge outlets: Open)

Maximum pressure: 80 kPa

Power consumption: Approx. 23 VA

Weight

For pure water: Approx. 65 kg

For raw water (1-cylinder): Approx. 70 kg

For raw water (2-cylinder): Approx. 75 kg

#### ■ Safety standard, EMC

Safety:

UL 61010-1, 61010-2-030

CSA C22.2 No.61010-1, 61010-2-030

GB30439

Installation altitude: 2000 m or less

Overvoltage category (IEC 61010): II (\*)

Pollution level (IEC 61010): 2 (\*\*)

(\*): Installation category, called over-voltage category, specifies impulse withstand voltage. Equipment with Category II is energy-consuming equipment to be supplied from the fixed installation.

(\*\*): Pollution level shows the level of existing the solid, liquid and gas which break electrical isolation. Category 2 is applied to normal room environment.

EMC:

RCM: EN 55011 Class A, Group 1

Korea Electromagnetic Conformity Standard

한국 전자파적합성 기준 Class A

## 2. Liquid Analyzer FLXA402T

Liquid Analyzer FLXA402T is common converter for Chlorine sensor unit and Turbidity detector. In this GS, only function and specification are provided for the connection between FLXA402T and RC800D.

#### ■ Chlorine display

Unit: mg/L, ppm,

You can input any letters by alphanumeric.

Display resolution: 0.000 to 9999

Regarding specification of detector, refer to 1.RC800D Reagent Type Free Available Chlorine Sensor Unit

#### ■ Electrical

Display

Display: QVGA color LCD with a touch screen

Message Language: English, German, French, Chinese, Korean, Spanish, Portuguese, Japanese

Note: You may find some image loss, uneven brightness, or afterimage on display. They are generated from the product features but not defects.

#### AC Power supply

Ratings: 100 to 240 V AC

Acceptable range; 90 to 264 V AC

Ratings: 50/60 Hz

Acceptable range; 50 Hz  $\pm 5\%$ , 60 Hz  $\pm 5\%$

Power Consumption: 35 VA

#### Output signal

Isolated outputs: 4-20 mA DC

Accuracy:  $\pm 0.02$  mA

Repeatability:  $\pm 0.02$  mA

Linearity:  $\pm 0.02$  mA

Maximum load: 600  $\Omega$

Number of outputs: 4 isolated outputs (-N4)

**Output range:** Configure within measurement range

Minimum range: minimum measurement range

Maximum range: maximum measurement range

Minimum span: 1 mg/L or more

(\*) In case auto range switching function is enable, low range is fixed by 0 mg/L.

### Automatic range switching function:

Ch1: No switching or switching in 2 or 3 points  
You can select the followings.

“Manual range switching, Remote range switching, Automatic 2 range switching, Automatic 3 range switching”

Ch2-Ch4: No switching or 2 range switching  
You can select the followings.

“Manual switching, Remote 2 range switching”

**Output function:** Linear output or 3 points polyline output (Set upper/lower value and another one point. The values between them are filled by linear.)

Output current; 3.4 to 21.6 mA

### Output signal during maintenance (HOLD):

Enable/Disable keep output value function during setting, calibration and maintenance (Automatic hold function)).

You can set HOLD value the last value or any value between 2.2 mA to 22.0 mA

### Burn out function (NAMUR 43)

Burn down: 2.2 mA

Burn up: 22.0 mA

### ■ Contact outputs

#### When -WR is selected.

Type: No-voltage contact output

Number: 4 contacts (S1/S2/S3/S4)

Contact S4 is for Fail-safe function.

Function: Selectable 4 functions among Alarm, maintenance mode, wash/calibration status, mA1 output range status.

Identification of range switching:

Contacts (S1/S2/S3) identifies mA output range. Up to 3 contacts are used for 3 ranges. Refer to User's manual when using 2 contacts to identify 3 ranges.

Switch capacity:

Maximum values; 100 VA, 250 V AC, 4A

Maximum values; 50 W, 24 V DC, 4A

### ■ Contact input

Type; Non-voltage contact output

Number; 2 contacts (-N4),

Function; Select among Remote 2range switching, Remote 3range switching  
Remote wash start, Remote calibration start, Disable

Remote range switching:

By contact input, mA output is switched to range “2” or range “3”. Range “3” is available only to mA1.

Short-circuit resistance (on resistance); maximum 200k  $\Omega$

Open resistance (off resistance); minimum 100k  $\Omega$

### ■ Digital communication (option)

Ethernet (Modbus TCP): 10/100 Mbps

Cable length: maximum 100 m

RS-485 (Modbus RTU): 115200/38400/9600 bps

Cable length:

115200 bps: maximum 600m

38400 bps, 9600 bps: maximum 1200m

### ■ Analog Input (mA, O/I code: -N4)

Temperature compensation

Isolation input; 4 to 20 mA DC

Accuracy;  $\pm 0.02$  mA

Input number; 1

### ■ Calibration, wash, diagnosis and other functions

Calibration function:

Zero calibration: Empty cell Zero calibration, Circuit noise adjustment, Zero Calibration by zero chlorine solution.

Slope calibration: Sample or solution

Automatic calibration function:

Automatic Zero Calibration\*  
(by Activated charcoal filtered water)

Automatic wash function:

Wash cell by pure water Sand filter flashing

Display maintenance information:

Operating time management  
(Replacement date of rotating contact, Measurement electrode operating time, Beads operating time, Motor operating time, Coupling operating time, Shaft assy operating time)

### ■ Mechanical and others

Housing: Aluminum alloy cast

Case

Color; Silver gray

Finish; Chemical resistant coating or high anti-corrosion coating

Window: Polycarbonate

Protection: IP66 NEMA Type 4X (USA), CSA Type 4X (Canada)

Please add Hood option (/H) in case of using outdoor

Size: 165×165×168.5 mm (W×H×D)

Not included cable gland

Weight: Maximum 1.5 kg

Terminal screw size; M3 (Earth terminal: M4)

Cable gland: 8 holes, M20 Cable gland x 8  
(For 6 to 12 mm outer diameter cable)

Note; Please screw up them by yourself

Conduit adopter (option):

G1/2, 1/2NPT or M20 × 1.5

Note: Please order required numbers.

Stainless Steel Tag Plate (option): In case you specified Option code /SCT, Tag plate which is printed numbers is shipped with product. You can attach this tag by wire.

Warm up time: Approx. 30 min

### ■ Safety standard, EMC

Safety:

UL 61010-1, 61010-2-030

CSA C22.2 No.61010-1, 61010-2-030

GB30439

Installation altitude: 2000 m or less

Overvoltage Category (IEC 61010): II (\*)

Pollution level (IEC 61010): 2 (\*\*)

(\*): Installation category, called over-voltage category, specifies impulse withstand voltage.

Equipment with Category II is energy-consuming equipment to be supplied from the fixed installation.

(\*\*): Pollution level shows the level of existing the solid, liquid and gas which break electrical isolation.

Category 2 is applied to normal room environment.

EMC:

RCM: EN 55011 Class A, Group 1

Korea Electromagnetic Conformity Standard

한국 전자파적합성 기준 Class A

### 3. Others

#### ■ Reagent Tank Model RC401G

##### (1) Reagent tank (RC401G-A)

Capacity: 100 L  
 Materials: Rigid PVC  
 Weight: Approx. 15 kg

##### (2) Reagent tank with stand (RC401G-B)

Incorporates the reagent tank in item (1) with a stand and a needle valve.

Stand materials: carbon steel  
 Stand color: Munsell 2.5Y8.4/1.2  
 Stand finish: Baked polyurethane resin coating  
 Weight: Approx. 25 kg

##### (3) Reagent mixing tank with cart (RC401G-C)

A reagent mixing tank mounted on a cart.  
 With manual mixer, and pump for transferring reagents.

(Note) This tank is for reagent preparation. It cannot be connected to RC400G pump directory.

Tank capacity: 100 L  
 Tank materials: Rigid PVC  
 Cart materials:  
 Frame; Steel pipe (SPG30A)  
 Bracket; Steel plate (SPCC)  
 Pump (Seal-less Pump):  
 Discharge flow rate; 14 to 35 L/min  
 Wetted part material; Polypropylene resin, Hastelloy, ceramics, fluorinated rubber  
 Power supply; 100 V AC, 50/60Hz  
 Power consumption; Approx. 100 VA  
 Power cord; PVC sheathed cable, 5 m  
 Weight; Approx. 40 kg

#### ■ Reagent (for one year)

##### (1) For free chlorine (-F)

Potassium bromide extra pure:  
 64 containers, 500 g each  
 Sodium acetate extra pure:  
 16 containers, 500 g each  
 Acetic acid extra pure:  
 17 containers, 500 ml each

##### (2) For residual chlorine (Total chlorine) (-T)

Potassium iodide extra pure:  
 8 containers, 500 g each  
 Sodium acetate extra pure:  
 3 containers, 500 g each  
 Acetic acid extra pure:  
 17 containers, 500 mL each

##### (3) For high concentration residual chlorine (Total chlorine) (-T)

Potassium iodide extra pure:  
 16 containers, 500 g each  
 Sodium acetate extra pure:  
 3 containers, 500 g each  
 Acetic acid extra pure:  
 17 containers, 500 mL each

##### (4) For combined chlorine insensitive version (Free chlorine) (-C)

Potassium bromide extra pure:  
 64 containers, 500 g each  
 Sodium acetate extra pure:  
 87 containers, 500 g each  
 Acetic acid extra pure:  
 4 containers, 500 mL each

(Note) These reagents sets are not imported from Japan because of both safety and transportation cost issues. Purchase them directly in your local reagent supplier.

## ■ Model & Suffix Codes

### RC800D Reagent Type Residual Chlorine Sensor Unit

Model	Suffix code	Option code	Description
<b>RC800D</b>	.....	.....	Reagent Type Residual Chlorine Sensor Unit
Measurement object (*1)	-F	.....	Free Available Chlorine (Free Chlorine)
	-C	.....	Combined Chlorine Insensitive Version (Free Chlorine) (*2)
	-T	.....	Residual Chlorine (Total Chlorine)
Type	-AB	.....	General purpose for RCM, China standard (*6)
	-AD	.....	General purpose for CSA (*6) (*7)
	-AG	.....	General purpose for KC
	-AJ	.....	General purpose
Sampling system (*3)	-1N	.....	For tap water/water distribution measurement (without sand filter)
	-2N	.....	For raw water measurement One sand Filter, with auto.cleaning
	-3N	.....	For raw water measurement DBL sand filters, with auto.cleaning
	-1A	.....	For tap water/water distribution measurement with auto.Zero calibration (without sand filter)
	-2A	.....	For raw water measurement One Sand Filter with auto.Zero calibration
	-3A	.....	For raw water measurement DBL sand filters with auto.Zero calibration
Stand material	-AB	.....	Carbon steel stanchion
	-SB	.....	Stainless steel stanchion
Sampling Power supply	-10	.....	100V AC, 50 Hz
	-11	.....	100V AC, 60 Hz
	-12	.....	110V AC, 50 Hz
	-13	.....	110V AC, 60 Hz
	-20	.....	200V AC, 50 Hz
	-21	.....	200V AC, 60 Hz
	-22	.....	220V AC, 50 Hz
	-23	.....	220V AC, 60 Hz
	Pump for Purging Air (*4)	-NA	.....
-P1		.....	Pump for Purging Air (100V, 50/60 Hz)
-P2		.....	Pump for Purging Air (110V, 50/60 Hz)
-P3		.....	Pump for Purging Air (200V, 50/60 Hz)
-P4		.....	Pump for Purging Air (220V, 50/60 Hz)
—	-NN	.....	Always -NN
—	-NN	.....	Always -NN
Option	/SCT	.....	Stainless Steel Tag Plate
	/CB3	.....	Conduit adapter G1/2×3 pcs (*8)
	/CD3	.....	Conduit adapter 1/2 NPT× 3 pcs (*8)
	/CF3	.....	Conduit adapter M20×1.5×3 pcs (*8)
	/ARS	.....	With Arrestor
	/NR	.....	Without reagent set for start-up (*5)

\*1: Measurement object selection is indicated in the following.

Application	Measurement object	
	Free chlorine	Total chlorine
Water purification: raw water	✓ (*1)	✓
Water purification: mixed water, sedimentation water	✓ (*1)	✓
Water purification mains water	✓	✓
Factory wastewater, treated effluent	N/A	N/A
Factory cooling water (industrial water)	N/A	✓ (*2)
Factory drinking water	✓	✓

✓: Can be measured  
N/A: Cannot be measured

\*1: If ammoniacal contaminants are present in large quantity, high concentrations of combined chlorine may remain if sampling is performed soon after chlorine injection in prechlorination treatment, or in intermediate treatment without prechlorination treatment. In this case, combined chlorine type is recommended.

\*2: Oxidizing or reducing agents other than chlorine may be present. If so, chlorine concentration measurement may not be possible.

\*2: Less affected by combined chlorine in free chlorine measurement.

\*3: Please contact Yokogawa regarding the adequate number of the sand filter.

\*4: Installation of Purging Air is required for all application. If instrument air cannot be used, select a Pump for Purging Air. Select the one with same voltage as sampling power supply.

\*5: When ordering the RC800D, select /NR and get reagent sets for start-up from local reagent supplier. These reagent sets can not be exported from Japan due to both safety and transportation issues.

\*6: When you select "-AB" or "-AD" and use sampling power of 100V or 110V, you cannot use any pump for purging air. Conduct purging with an instrument air.

\*7: When you select "-AD" (CSA), "/ARS" cannot be selected.

\*8: See ● Required number of conduit adapters. The connection of power supply uses 1 conduit. After completing conduit work on RC800D, you can use the unused conduit adapters for the conduit of FLXA402T.

## ■ Accessories

Name	Q'ty	Remarks
Polishing powder (Alumina)	1 Bottle	For polishing electrode
Lubricant	1	For Liquid flow pump drive
Glass beads	1	2 bags / 1 Q'ty (including spare)
Valve sheet	4	For Liquid flow pump (for spare)
Bellophram	1	For sample pump (for spare)
	1	For reagent pump (for spare)
Tool	1	For Valve sheet replacement
Hardware for Bellophram	1 set	For Bellophram replacement
Allen wrench	1 set	Nominal size: 1.5, 2, 2.5, 4, 5, 6 mm

## ■ Spare parts

Recommended replacement interval described here is values based on our guidance but not a warranty for the period.

Name	Part No.	Description	Frequency of Replacement
Measurement Electrode (rotating electrode)	K8005JC	Gold alloy electrode	Yearly
Reference electrode	K8005UH	Platinum electrode (-F, -T)	*1
Reference electrode	K8005UC	Silver/Silver chloride electrode for combined chlorine insensitive type, (-C)	*1
Glass beads	K9332ZJ	2 packs / piece	Yearly
Rotating contact	K9332SR	Part for the electrode unit	Yearly
Driven shaft assembly	K8005LB	Part for the electrode unit	3 years
O-ring	Y9115XB	Part for the electrode unit	3 years
Motor	K8005LC	Part for the electrode unit	3 years
Coupling	B1005AC	Part for the electrode unit	3 years
Fuse	A1633EF	250V/2.5A for the smart unit	—
Fuse	A1624EF	250 V/3.15 A for the relay box The relay box uses two fuses.	—
Sand for filter	K9720FZ	1 L for the sand filter (-2N,-3N,-2A,-3A)	Yearly
Air pump (100V)	K9087XA	For the Air pump (-P1)	3 years
Air pump (110V)	K9087XF	For the Air pump (-P2)	3 years
Air pump (200 V)	K9087XG	For the Air pump (-P3)	3 years
Air pump (220 V)	K9087XH	For the Air pump (-P4)	3 years
Lubricating oil	K9041RA	For liquid pump monthly maintenance	1 month *2
Bellophram	L9819AA	For reagent flow control of liquid pump	6 Months
Bellophram	L9819AB	For sample flow control of liquid pump	6 Months
Valve sheet	K9041HC	For liquid pump RC800D has 2 liquid pumps.	6 Months
	K9041SU	4 pcs of K9041HC	
Activated charcoal filter	L9862AY	For zero calibration	Yearly
Filter	K9332NN	Parts of the sand filter (-2N,-3N,-2A,-3A)	Yearly

\*1: Replace them when damaged.

\*2: This is recommended frequency.

### ● Required Number of Conduit Adapters

If you need to perform conduit work on cables, specify the conduit adapter by Option code.

Conduit adapters and dedicated cable glands, which are used in place of the standard cable gland for cable entry holes, are supplied with the product.

You can specify the conduit adapter by Option code for both RC800D and FLXA402T, however, be aware of the following.

- When FLXA402T Digital communication “-E” (Modbus TCP/IP) is selected

If you attach a conduit adapter on the Modbus TCP/IP (Ethernet) cable entry, you need an Ethernet dedicated conduit adapter. Be sure to specify FLXA402T “/C□6”.

Next diagram shows the position of each cable entry (●) where you can attach conduit adapters for the conduit.

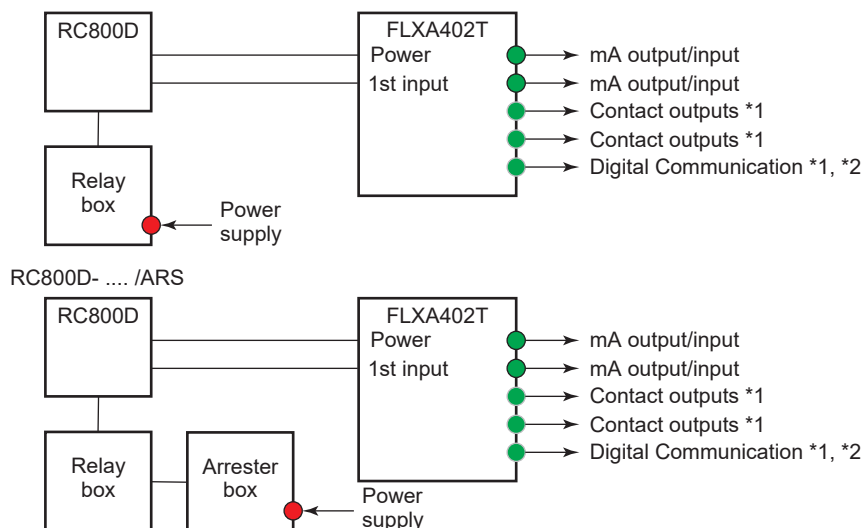

\*1: The number of cable entry holes to be used are defined by the specification as below.

Spec. Code	Contact Outputs		Digital Communication		
	-WR	-NR	-N	-E	-R
<b>Required No. of cable entry holes</b>	2	0	0	1*	1

\*: Conduit exclusively for Ethernet

\*2: For Ethernet cable, use Ethernet dedicated conduit adapter.

If you need more conduit adapters to meet the requirement, purchase additionally. See the table below.

#### Conduit adapter (for additional purchase)

Type	Parts number	Quantity	Remark
G 1/2 (Cable gland for adapter + adapter)	K9703WF	4 set	for Option code /CB□
1/2 NPT (Cable gland for adapter + adapter)	K9703WG	4 set	for Option code /CD□
M 20 x 1.5 (Cable gland for adapter + adapter)	K9703WH	4 set	for Option code /CF□



## FLXA402T Liquid Analyzer for Turbidity and Chlorine

Liquid Analyzer FLXA402T is a common analyzer for Turbidity and Chlorine. The table below for Model and Suffix code (MS code) applies the combination between FLXA402T and RC800D.

Model	Suffix code	Option code	Description
FLXA402T	.....	.....	Liquid Analyzer for Turbidity and Chlorine
Power supply	-A	.....	AC version
Housing (*1)	-B -D	..... .....	Aluminum alloy cast + urethane coating Aluminum alloy cast + high anti-corrosion coating
Type (*2)	-AB -AD -AG -AJ	..... ..... ..... .....	General purpose for RCM, China standard General purpose for CSA General purpose for KC General purpose
1st Input	-CL	.....	SENCOM SA for Chlorine
2nd Input	-NN	.....	Without Input
mA Output/Input	-N4	.....	4 x 4-20 mA Output + 2 x Contact Input + 1 x 4-20 mA Input (without HART)
Contact Outputs	-WR -NR	..... .....	Contact outputs (Wash and Fail contact outputs) Without Contact outputs (without Wash and Fail contact outputs)
-	-N	.....	Always -N
Digital Communication	-N -E -R	..... ..... .....	Without Digital communication Modbus TCP/IP Modbus RTU (RS-485)
Country (*5)	-N -J	..... .....	Global except Japan Japan
Assembled in stanchion	-ST	.....	Assembled in stanchion
-	-NN	.....	Always -NN
Option	Tag plate Conduit adapter (*3)	/SCT /CB4 /CD4 /CF4 /CB6 /CD6 /CF6	Stainless steel tag plate G1/2 x 4 pcs 1/2NPT x 4 pcs M20 x 1.5 x 4 pcs G1/2 x 3 pcs + G 1/2 for Ethernet x 1 pcs (*4) 1/2NPT x 3 pcs + 1/2 NPT for Ethernet x 1 pcs (*4) M20 x 1.5 x 3 pcs + M20 for Ethernet x 1 pcs (*4)

\*1: Urethane coating is acid resistant. Heavy duty coating is acid/alkali resistant.

\*2: Always select same Type as sensors for use.

\*3: See ● Required Number of Conduit Adapters.

\*4: Available only when “-E” (Modbus TCP/IP) to digital communication is selected.

\*5: Select only “-J” if you use the converter in Japan. Only SI unit (International System of Units) applies

### ■ Optional parts

Name	Parts number	Quantity	Remark
Rubber plug attachment	K9334CN	1 pcs	for Cable gland
Fuse	A1633EF	1 pcs	250V/2.5A (minimum 5 pcs)
SD card	A1005NL	1 pcs	2 GB industrial SD card (with power failure recovery) Customers can provide the cards with spec: Storage capacity: 128 MB or greater Type: SD, SDHC

## RC401G Reagent tank

Model	Suffix code	Option code	Description
RC401G	-----	-----	Reagent tank
Type	-A	-----	Reagent tank only
	-B	-----	Reagent tank with stand
	-C	-----	Reagent mixing tank with mobile stand
-	-HM	-----	With manual mixer
-		*A	Style A

### ■ Accessories for Reagen tank (RC401G-A, RC401G-B)

Name	Q'ty	Remark
Couplings	2 sets	
Polyethylene tubing	5 m	Outside diameter 6 mm, Inside diameter 4 mm.

Note: These are not included in reagent mixing tank (RC401G-C.)  
Reagents are not imported from Japan because of both safety and transportation cost issues. Purchase them directly from your local reagent supplier.

■ Dimensions

(1) RC800D Reagent Type Residual Chlorine Sensor Unit

For tap water/water distribution measurement (without sand filter) (Sampling system: -1N, -1A)

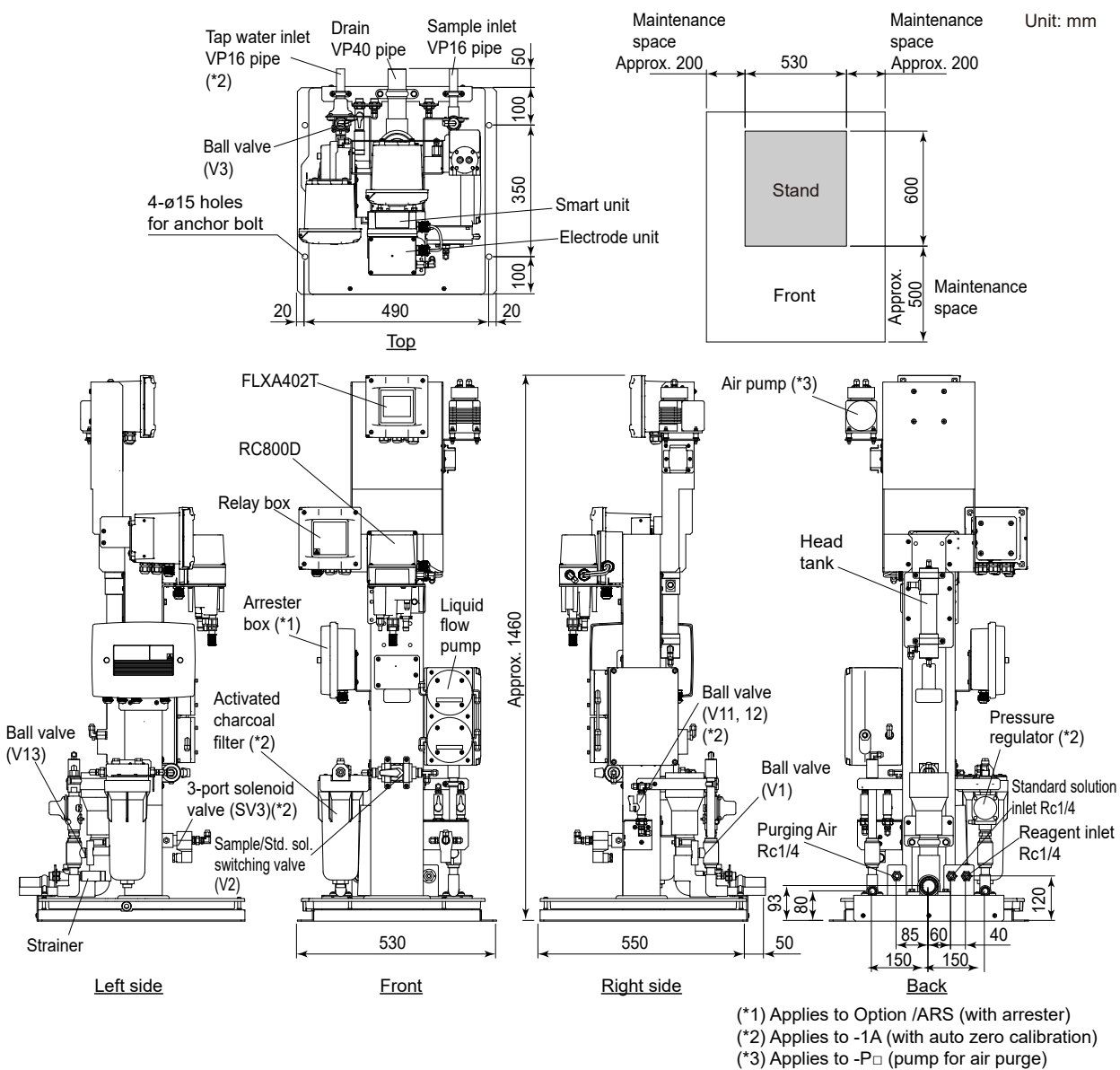

(2) For raw water measurement One Sand Filter, with auto. cleaning (Sampling system: -2N, -2A)

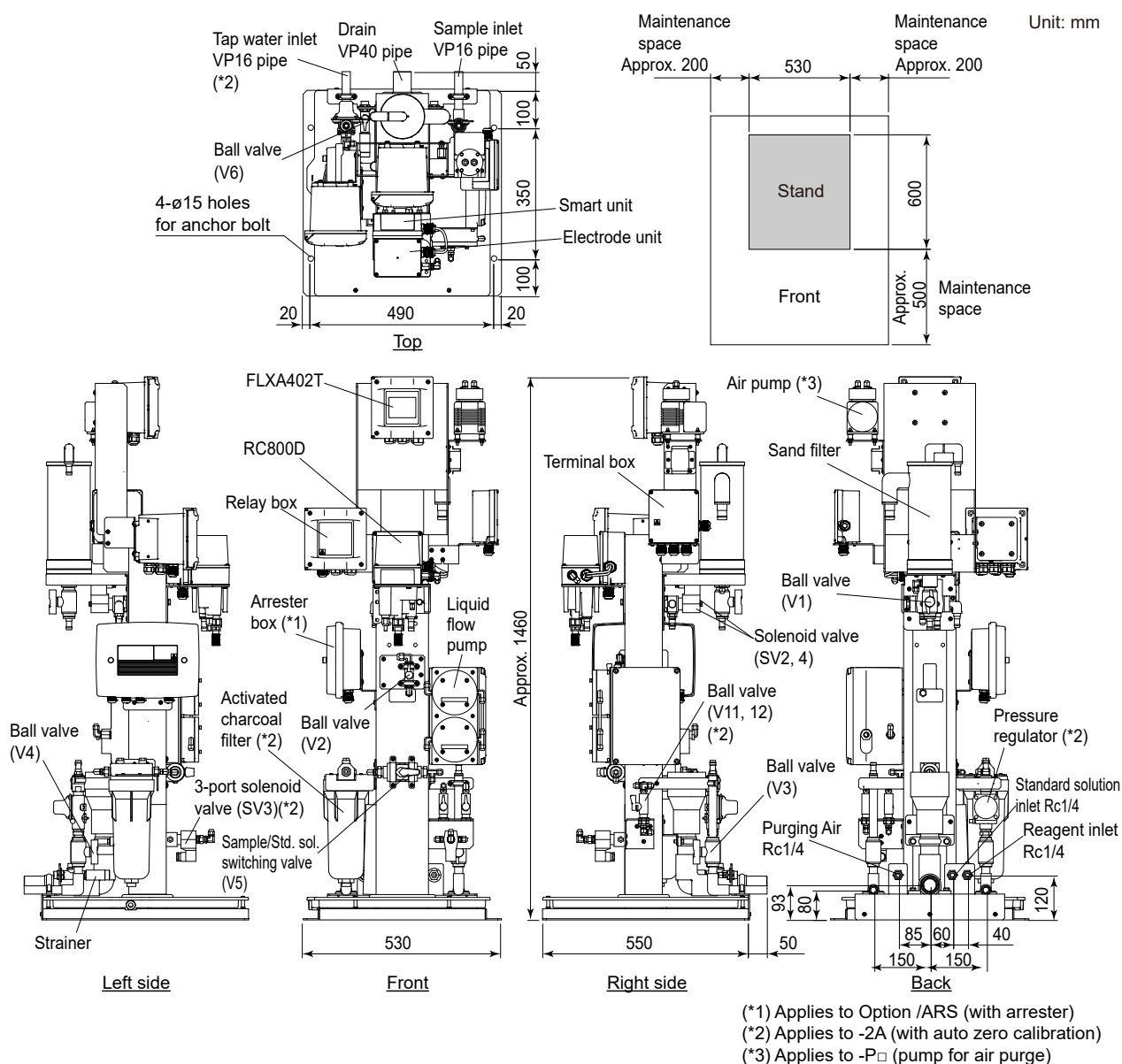

**(3) For raw water measurement DBL sand filter, with auto.cleaning (Sampling system: -3N, -3A)**

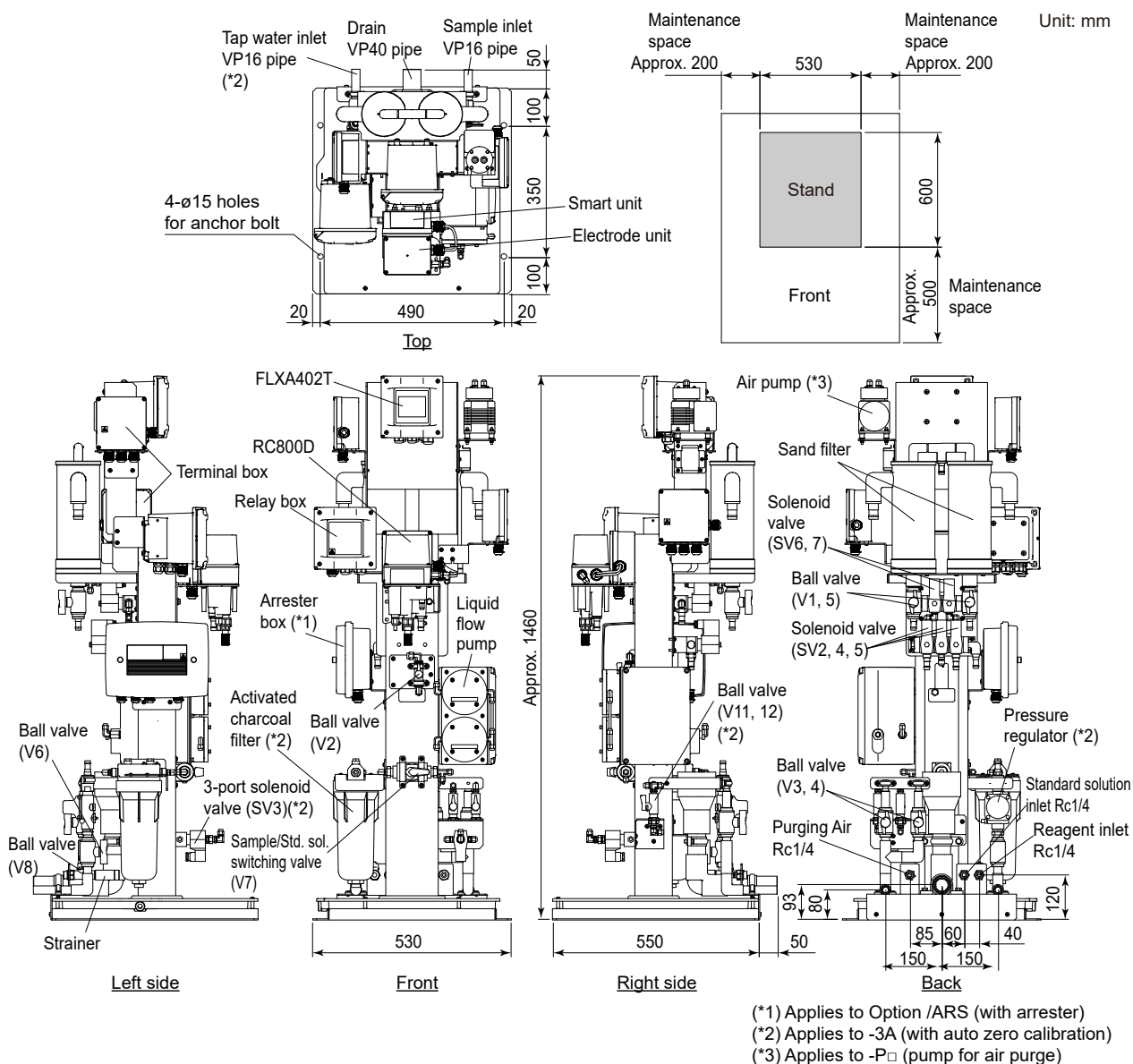

● **Conduit adaptor (/CB3, /CD3, /CF3/)**

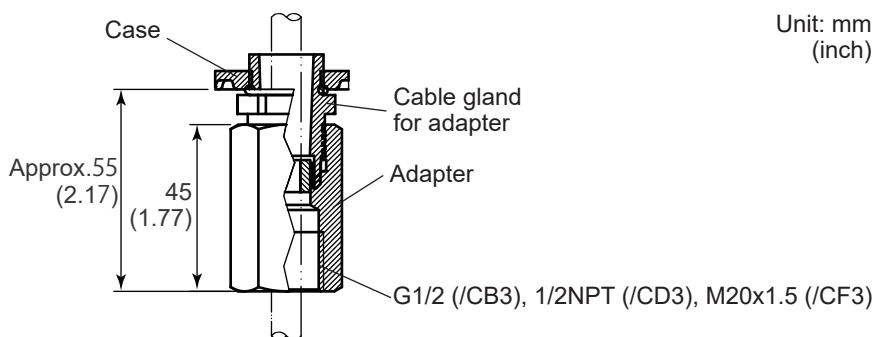

**FLXA402T Liquid Analyzer for Turbidity and Chlorine**

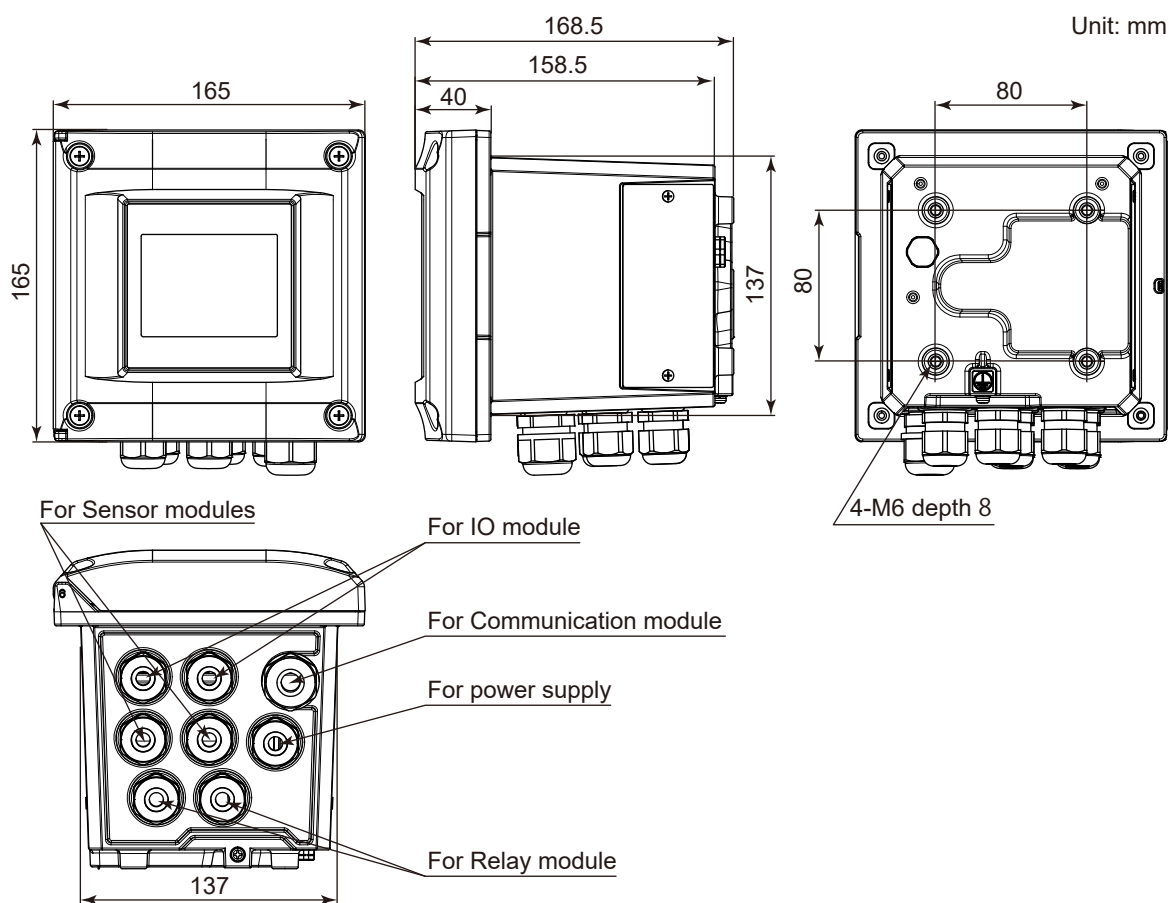

**Conduit adaptor (/CB4, /CD4, /CF4/, /CB6, /CD6, /CF6)**

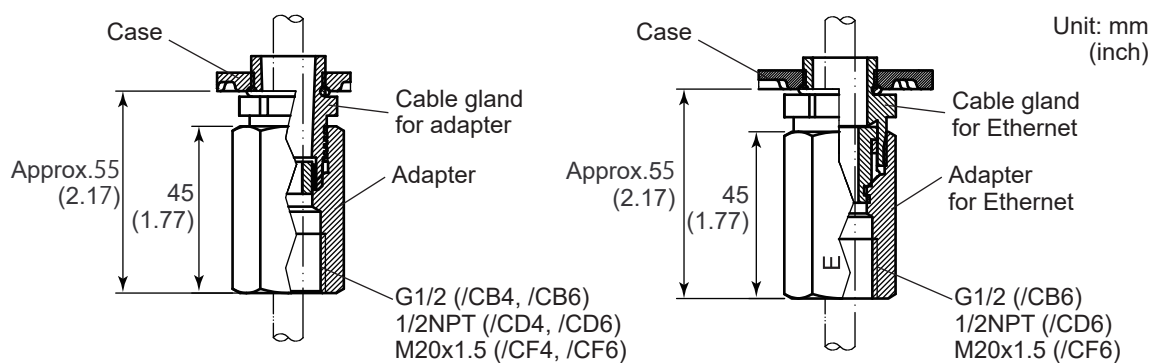

**(4) Reagent tank**

- Reagent tank (RC401G-A)

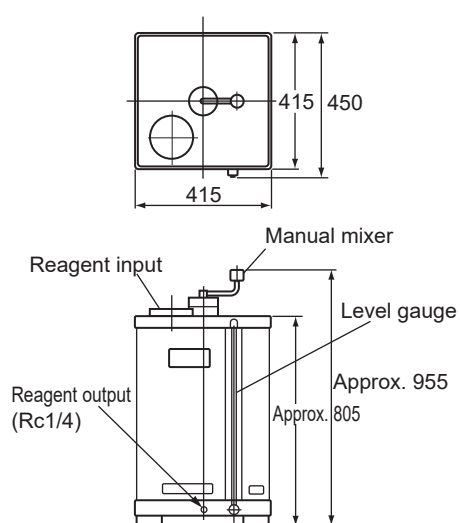

- Reagent tank with stand (RC401G-B)

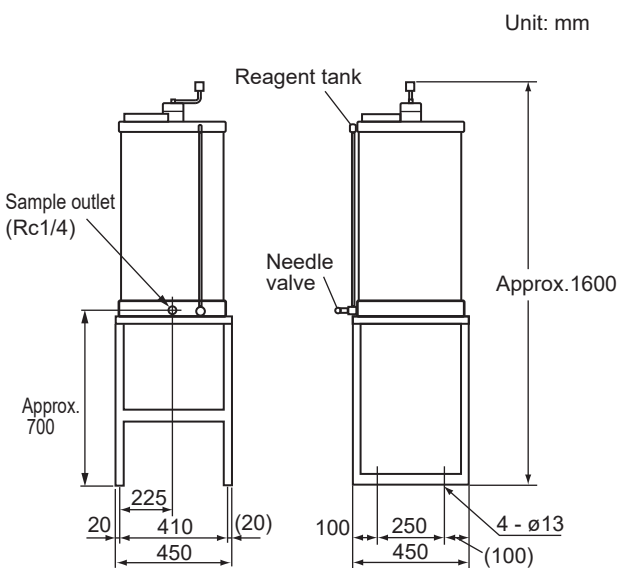

- Reagent mixing tank with mobile stand (RC401G-C)

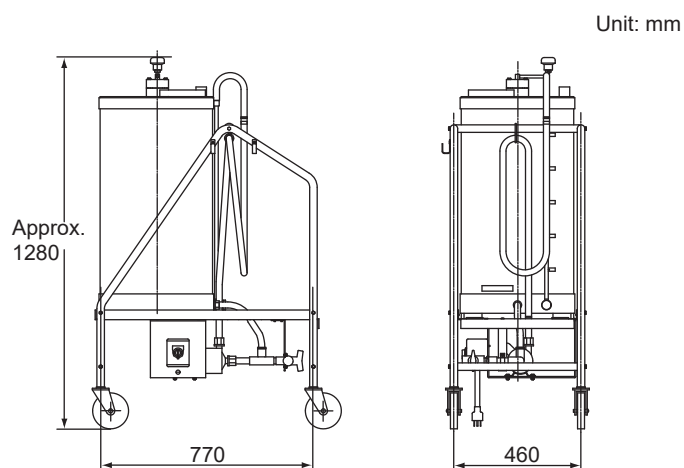

## ■ Piping

### (1) For tap water/water distribution measurement (without sand filter) (Sampling system: -1N, -1A)

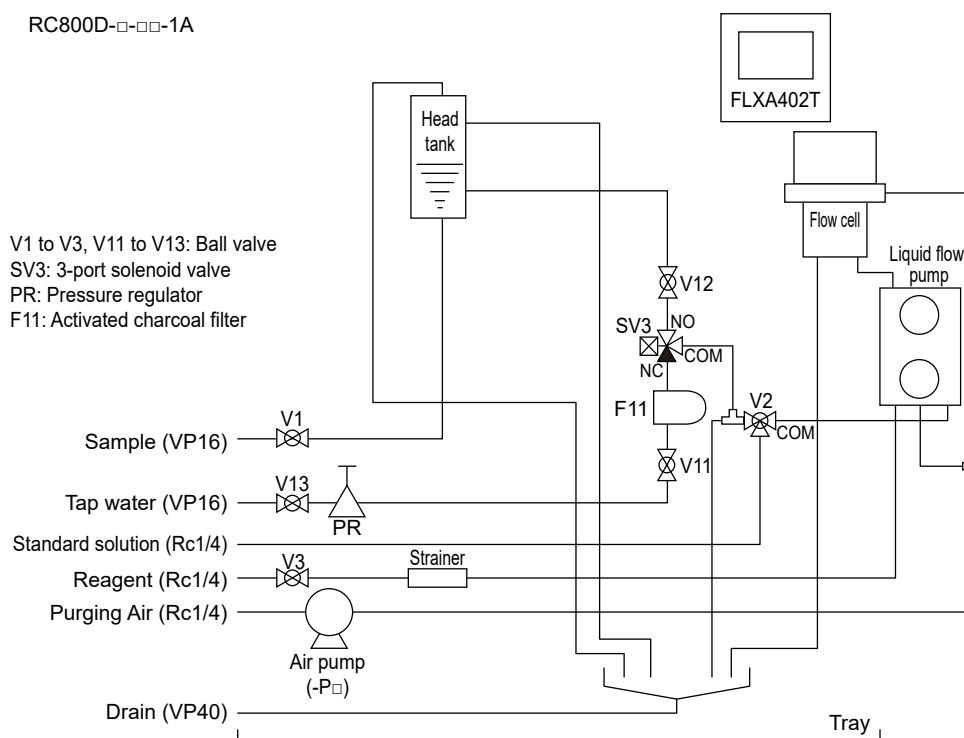
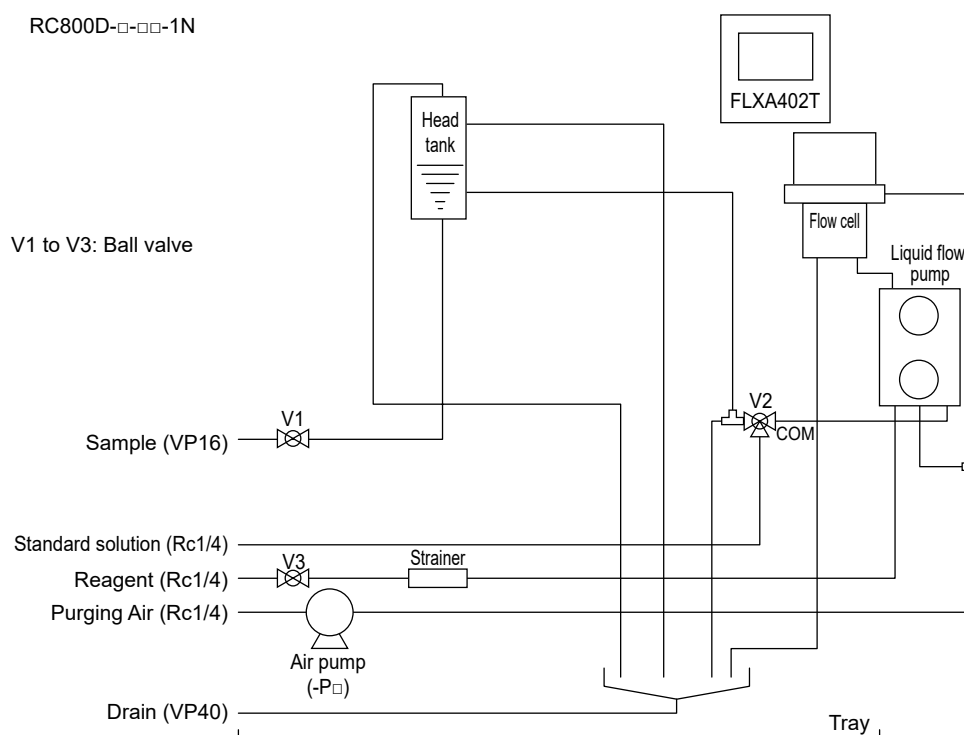



(2) For raw water measurement One Sand Filter, with auto. cleaning (Sampling system: -2N, -2A)

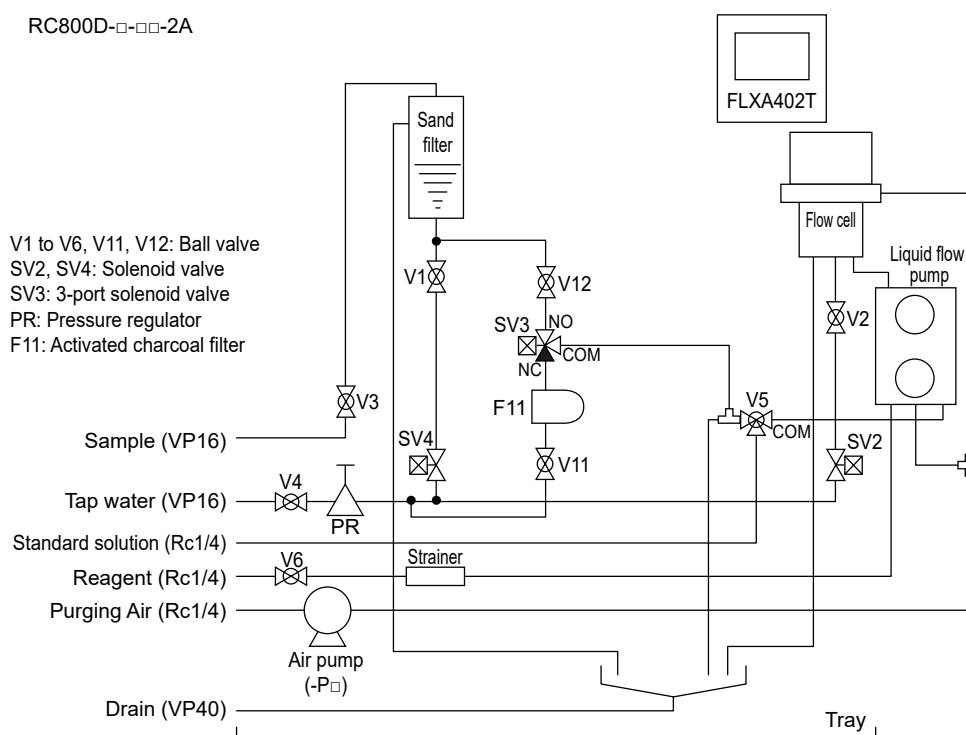
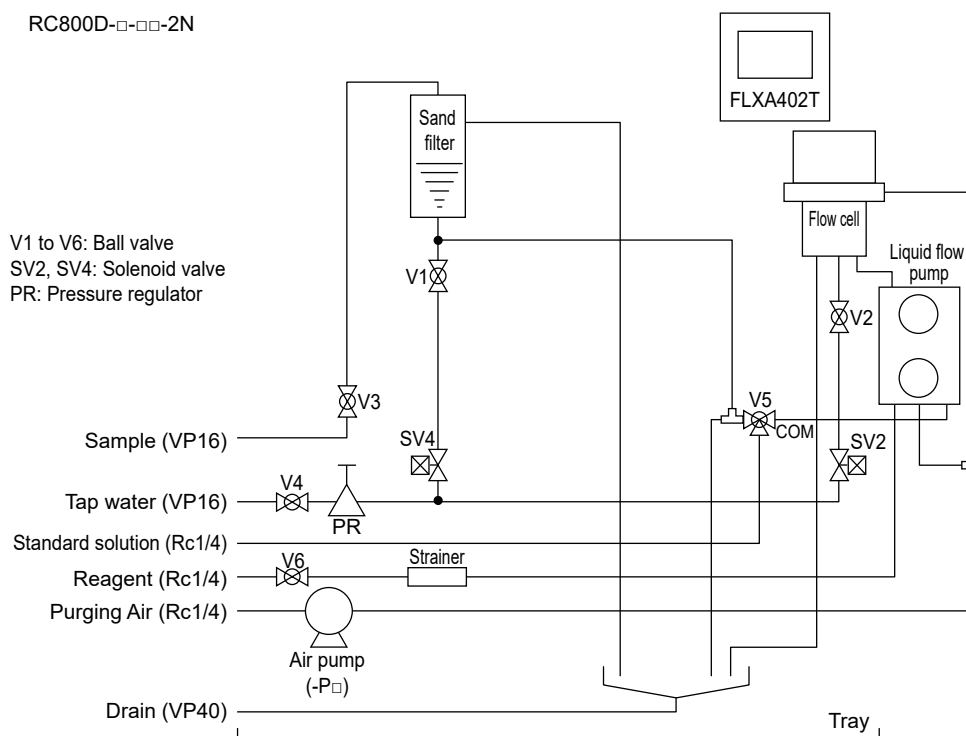

(3) For raw water measurement DBL sand filter, with auto.cleaning (Sampling system: -3N, -3A)

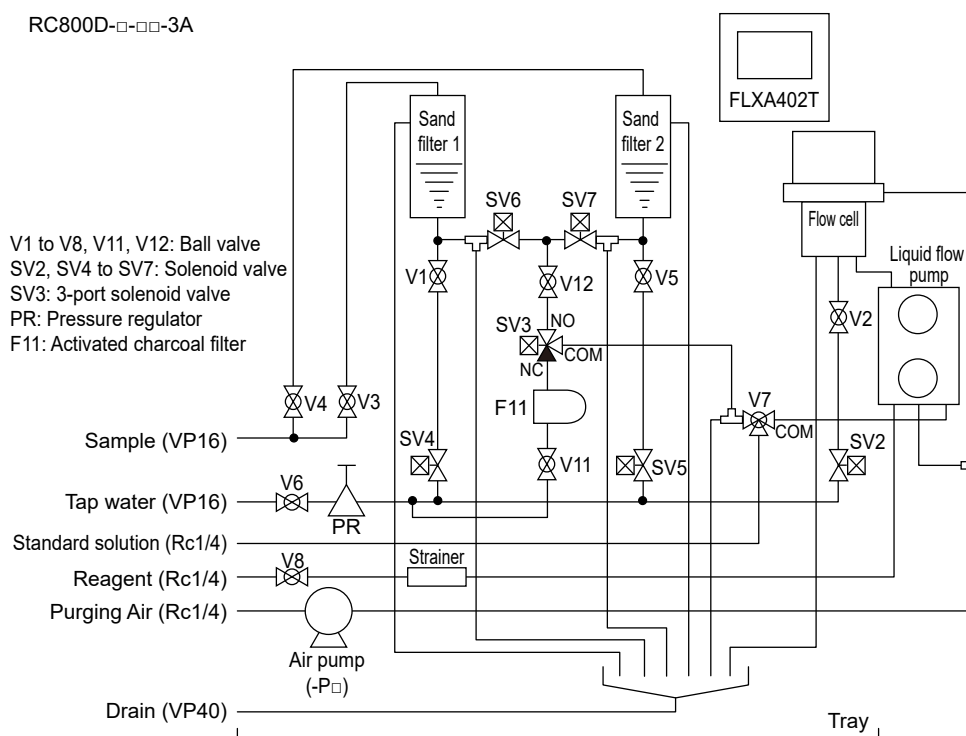
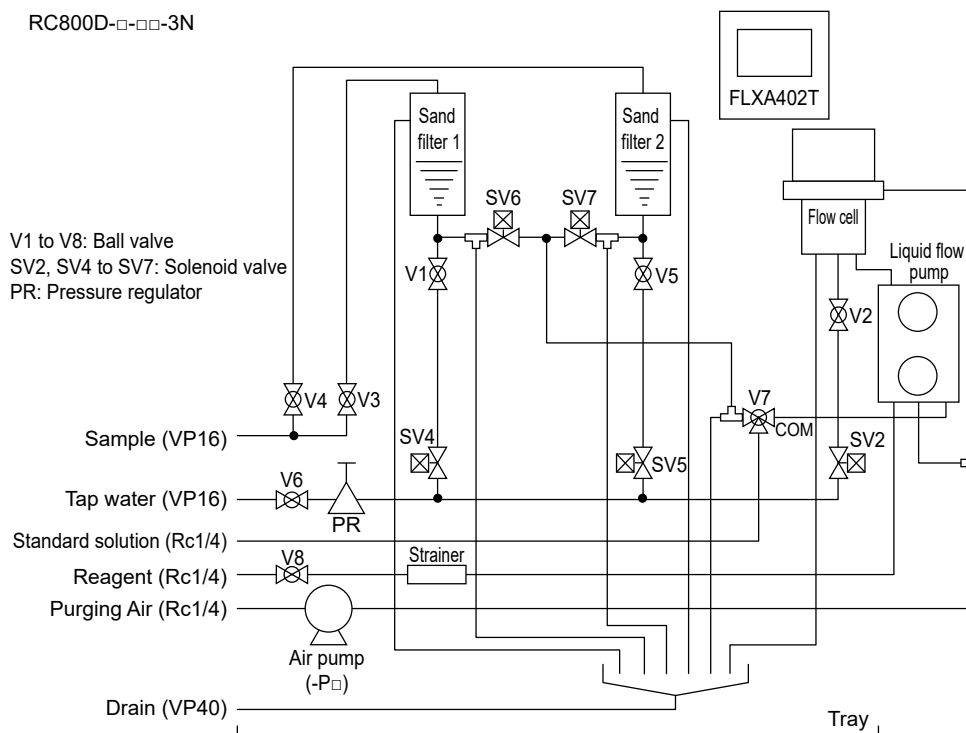

## ■ Wiring

### (1) For tap water/water distribution measurement (without sand filter) (Sampling system: -1N, -1A)

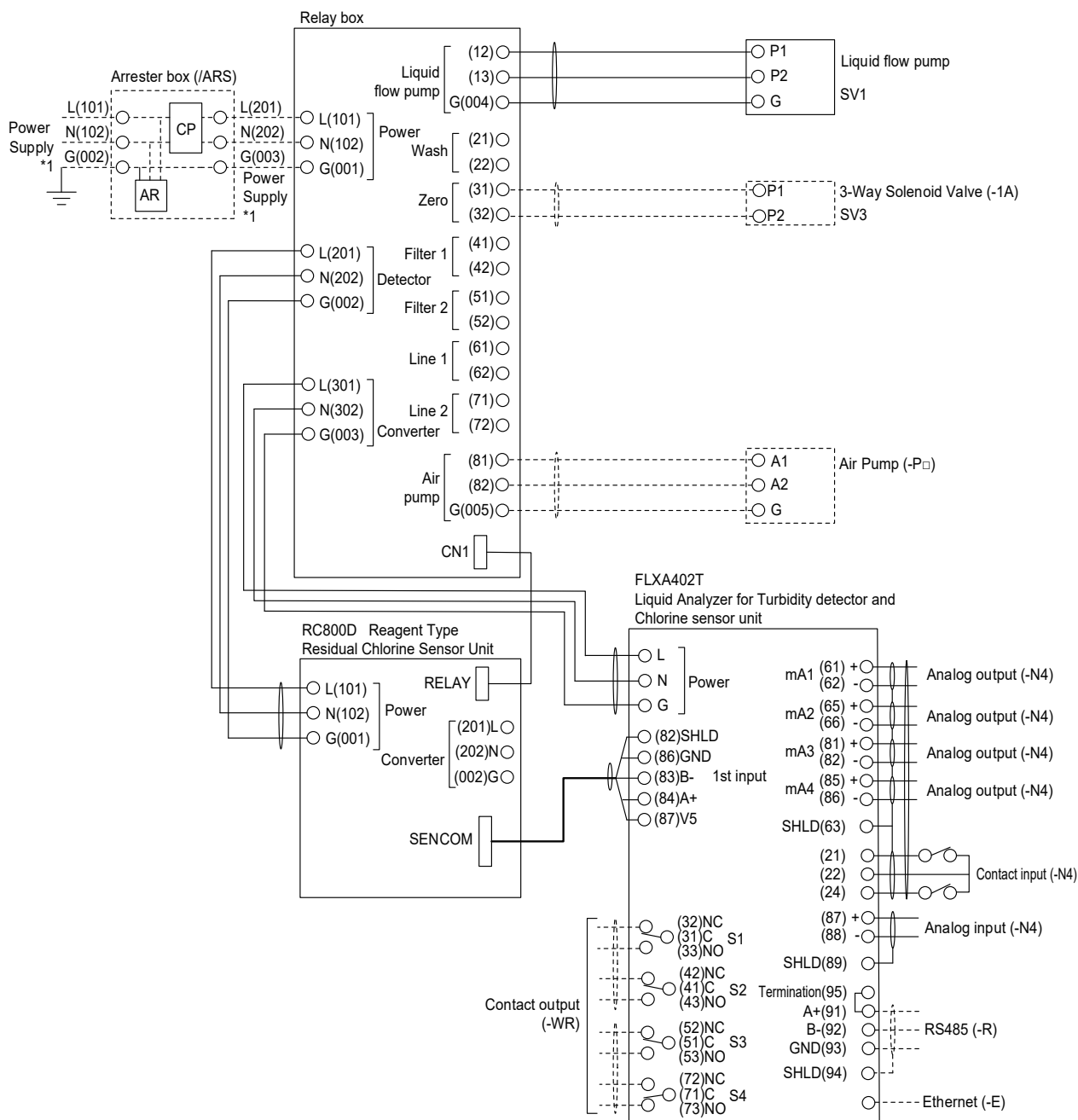

**(Note)**

- \*1: Power terminal "G" on Relay box or Arrester box must be grounded (ground resistance: 100 ohm or less).  
 In case of selecting /ARS, power supply cable connects with L(101), N(102) and G(001) in Arrester box.  
 In case of not selecting /ARS, power supply cable connects with L(101), N(102) and G(002) in Relay box.

## (2) For raw water measurement One Sand Filter, with auto. cleaning (Sampling system: -2N, -2A)

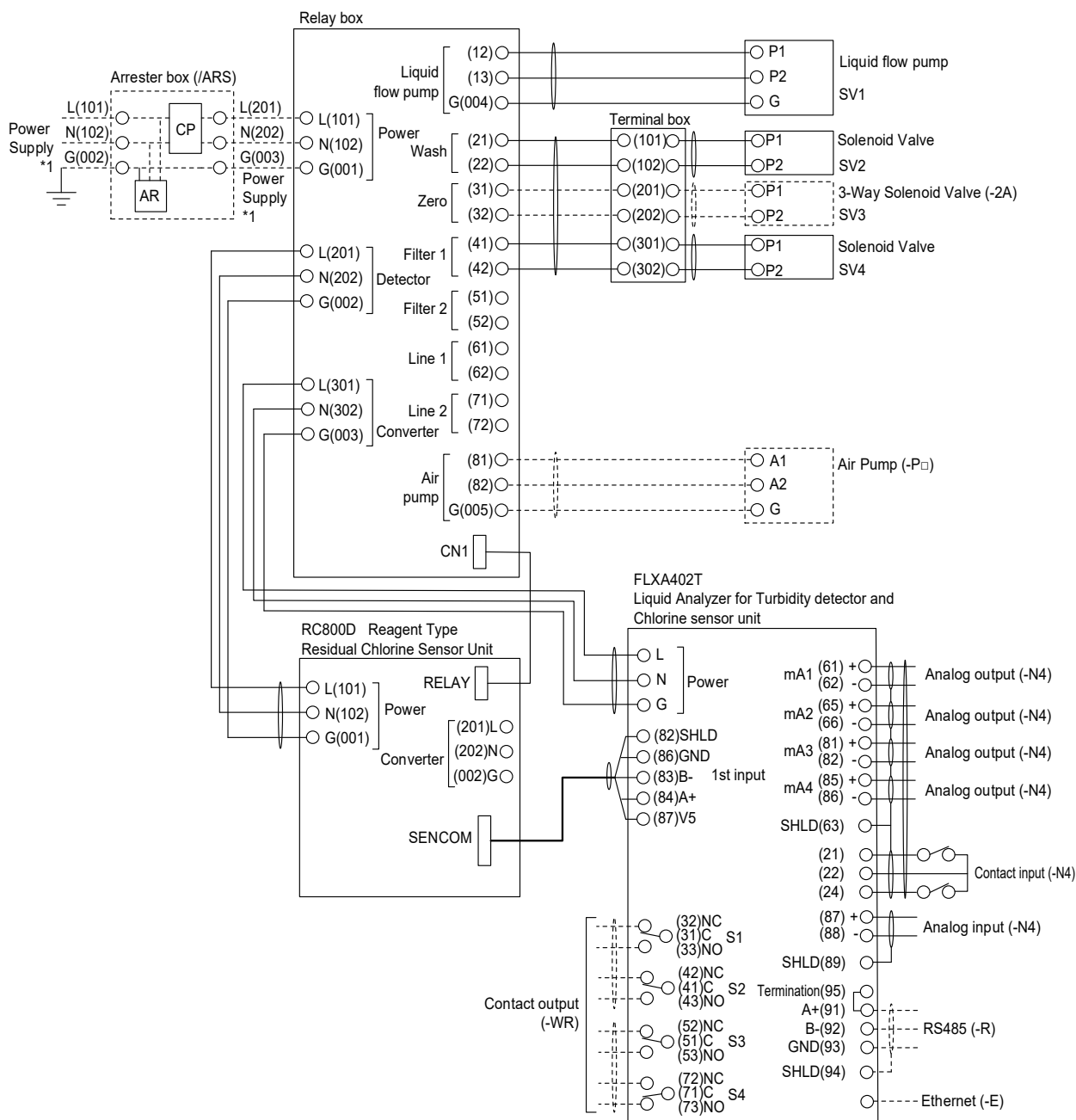

(Note)

- \*1: Power terminal "G" on Relay box or Arrester box must be grounded (ground resistance: 100 ohm or less).  
 In case of selecting /ARS, power supply cable connects with L(101), N(102) and G(001) in Arrester box.  
 In case of not selecting /ARS, power supply cable connects with L(101), N(102) and G(002) in Relay box.

### (3) For raw water measurement DBL sand filter, with auto.cleaning (Sampling system: -3N, -3A)

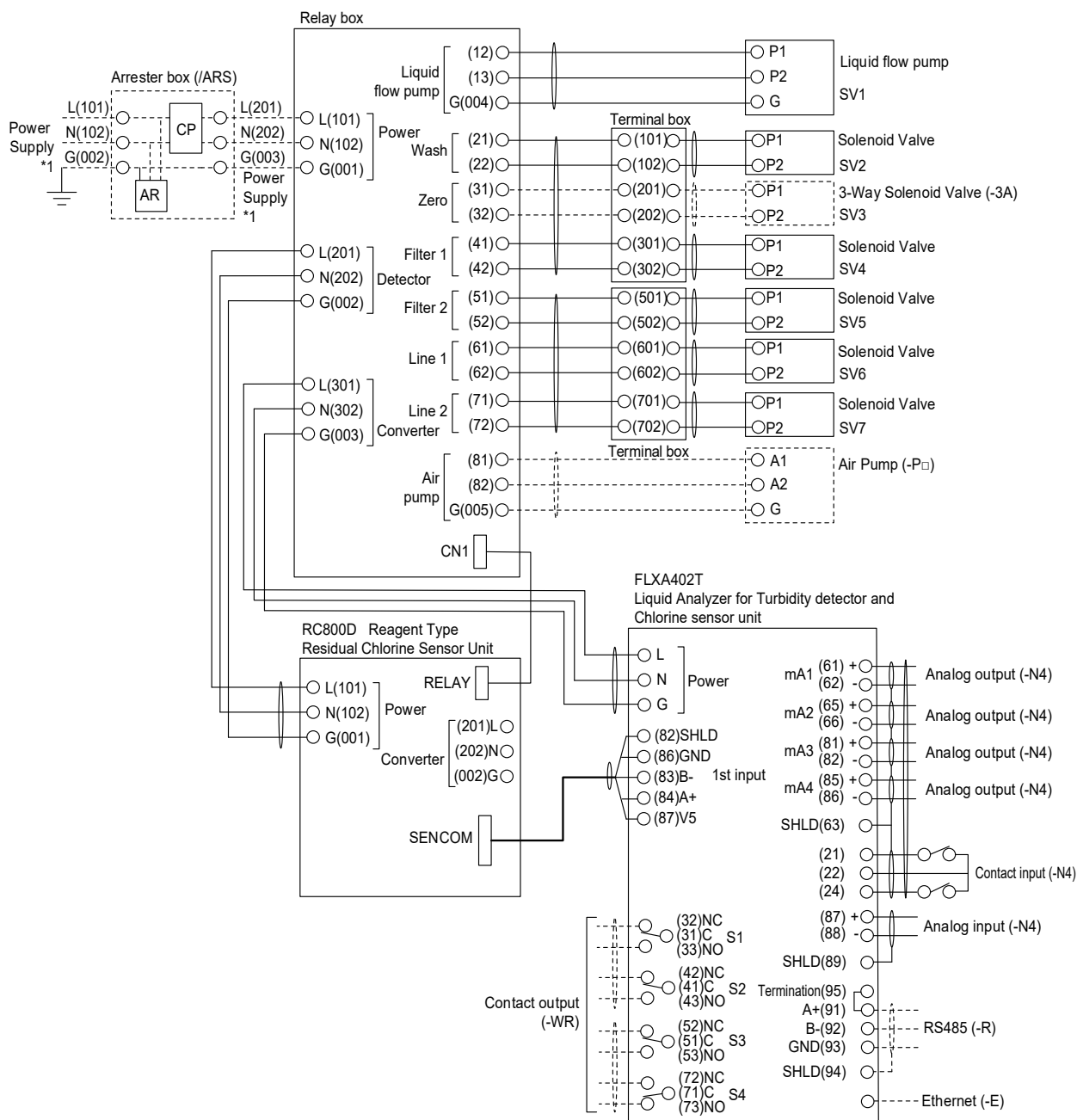

(Note)

\*1: Power terminal "G" on Relay box or Arrester box must be grounded (ground resistance: 100 ohm or less).

In case of selecting /ARS, power supply cable connects with L(101), N(102) and G(001) in Arrester box.

In case of not selecting /ARS, power supply cable connects with L(101), N(102) and G(002) in Relay box.